

LFP7ZL-BS (12V2.5Ah)

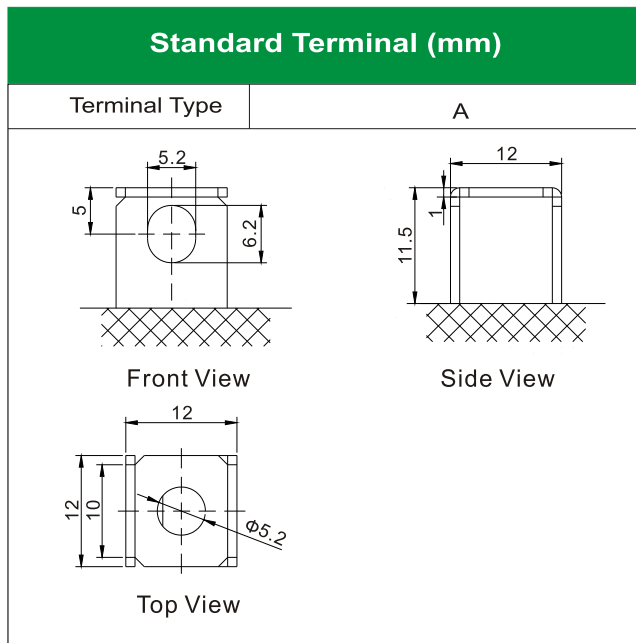
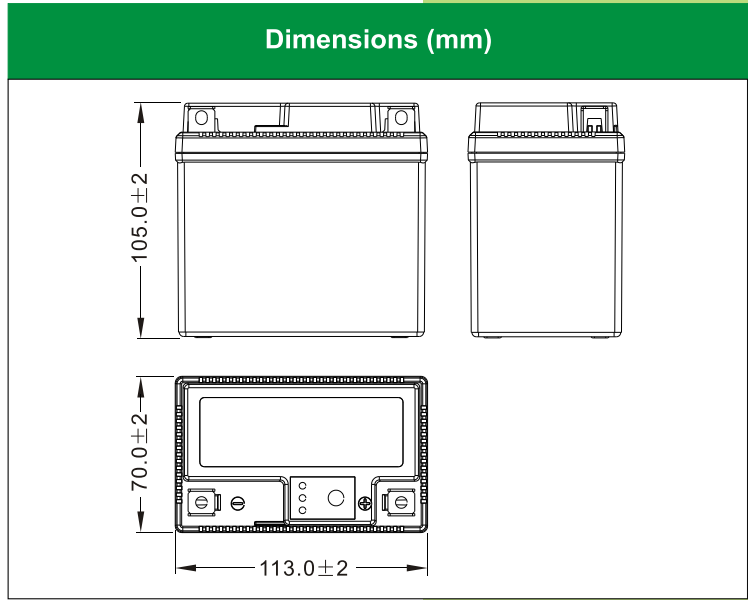

Physical Specification

Nominal Voltage	12V	
Nominal Capacity (10HR)	2.5AH	
Dimension	Length	113 ± 2mm (4.45 inches)
	Width	70 ± 2mm (2.76 inches)
	Container Height	105 ± 2mm (4.13 inches)
	Total Height (with Terminal)	105 ± 2mm (4.13 inches)
Weight	Battery(with acid): Approx 0.55kg (1.21lbs)	

- * Motorcycle Li-ion battery
- * Maintenance-free
- * Powerful 125 cranking amps
- * Shipped pre-charged and ready to install
- * Replaces YTX5L-BS/YTX7L-BS/YTZ5S/YB7C-A battery

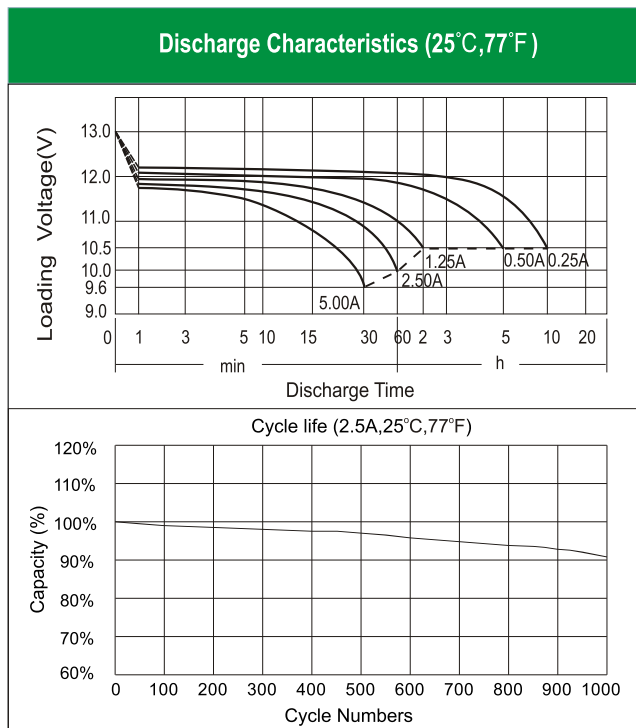

Electrical Specification

Rated Capacity	10 hour rate (0.25 A)	2.50AH
	5 hour rate (0.50 A)	2.50AH
	2 hour rate (1.25 A)	2.50AH
	1 hour rate (2.50 A)	2.50AH
	0.5 hour rate (5.00 A)	2.50AH
Capacity affected by Temperature	40 °C (104 °F)	98%
	25 °C (77 °F)	100%
	0 °C (32 °F)	85%
	-20 °C (-4 °F)	70%
Self Discharge	Approximately 1.5% per month (25°C (77°F))	
Charging Methods	Full Charge	Constant-Voltage Charge: Initial charging current: less than 0.5A Voltage: 14.40 V ~ 14.60 V at 25 °C (77 °F)