

LFP14Z-BS [12V5Ah]

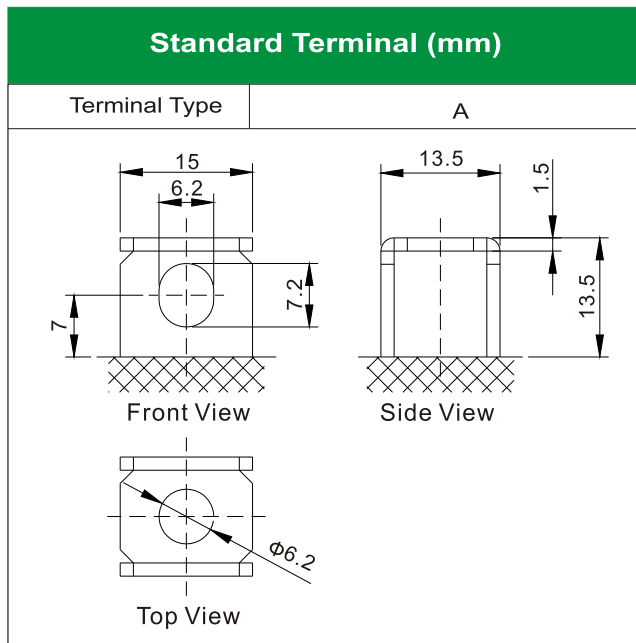
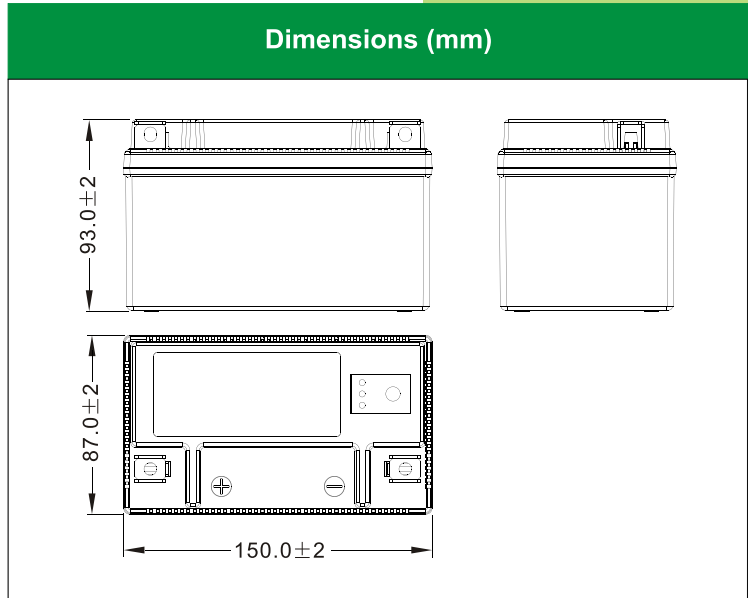

Physical Specification

Nominal Voltage	12V	
Nominal Capacity (10HR)	5AH	
Dimension	Length	150 ± 2mm (5.91 inches)
	Width	87 ± 2mm (3.43 inches)
	Container Height	93 ± 2mm (3.66 inches)
	Total Height (with Terminal)	93 ± 2mm (3.66 inches)
Weight	Battery(with acid): Approx 1.10kg (2.42lbs)	

- * Motorcycle Li-ion battery
- * Maintenance-free
- * Powerful 250 cranking amps
- * Shipped pre-charged and ready to install
- * Replaces YTZ10S/YTZ12A-BS/YTZ12S/YTX12-BS/YTZ14S/YB12B-B2 battery

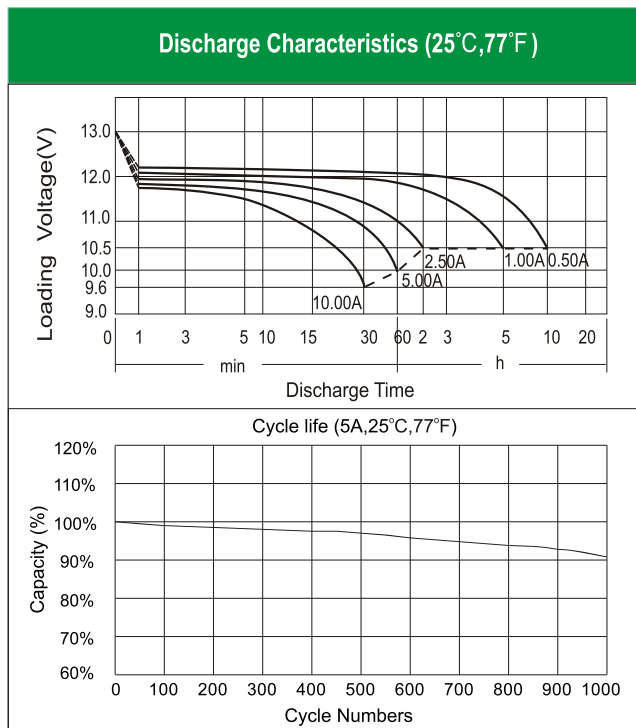

Electrical Specification

Rated Capacity	10 hour rate (0.50 A)	5.00AH
	5 hour rate (1.00 A)	5.00AH
	2 hour rate (2.50 A)	5.00AH
	1 hour rate (5.00 A)	5.00AH
	0.5 hour rate (10.00 A)	5.00AH
	Capacity affected by Temperature	40 °C (104 °F)
	25 °C (77 °F)	100%
	0 °C (32 °F)	85%
	-20 °C (-4 °F)	70%
Self Discharge	Approximately 1.5% per month (25°C (77°F))	
Charging Methods	Full Charge	Constant-Voltage Charge: Initial charging current: less than 1.0A Voltage: 14.40 V ~ 14.60 V at 25 °C (77 °F)