

# LFP12-BS (12V6Ah)

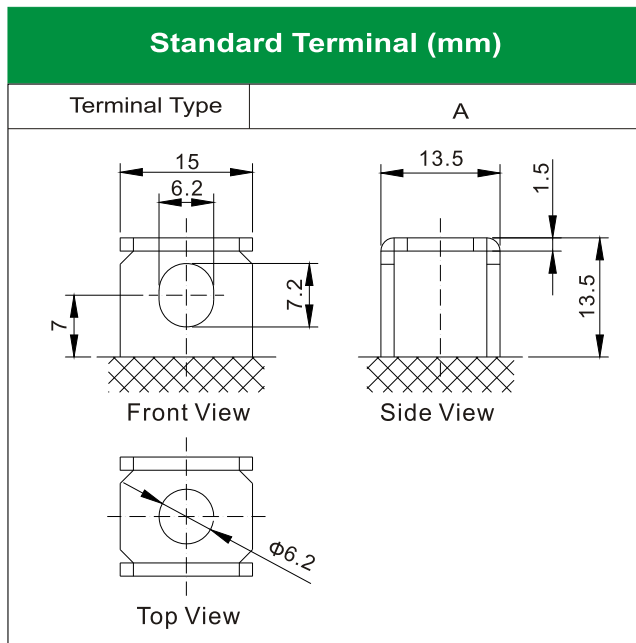
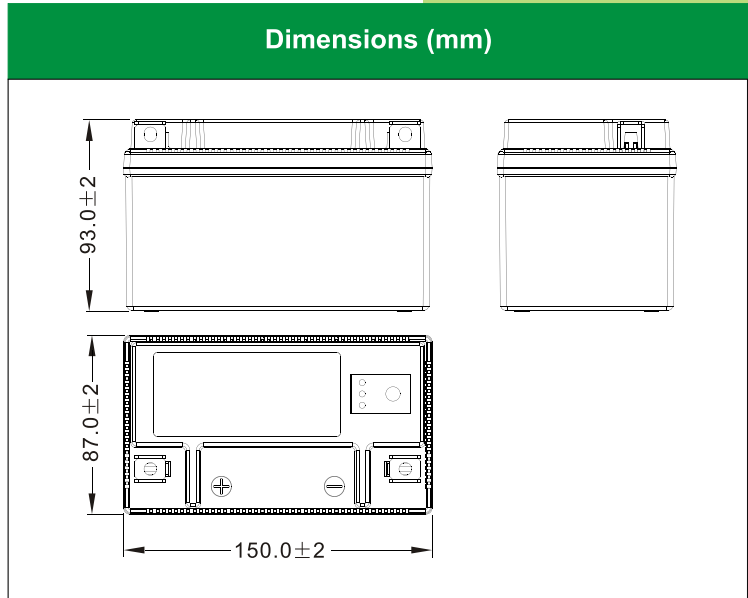

### Physical Specification

Nominal Voltage	12V	
Nominal Capacity (10HR)	6AH	
Dimension	Length	150 ± 2mm (5.91 inches)
	Width	87 ± 2mm (3.43 inches)
	Container Height	93 ± 2mm (3.66 inches)
	Total Height (with Terminal)	93 ± 2mm (3.66 inches)
Weight	Battery(with acid): Approx 0.95kg (2.09lbs)	

- \* Motorcycle Li-ion battery
- \* Maintenance-free
- \* Powerful 180 cranking amps
- \* Shipped pre-charged and ready to install
- \* Replaces YTZ10S/YT12A-BS battery

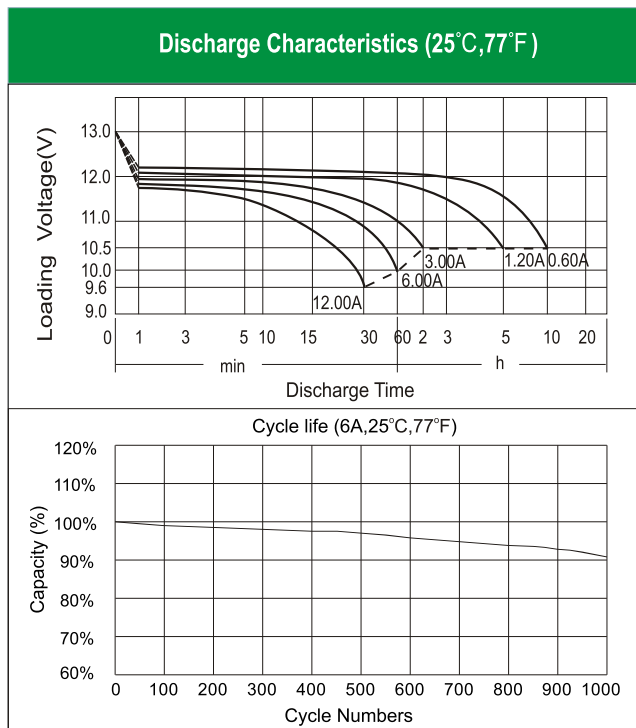

### Electrical Specification

Rated Capacity	10 hour rate (0.60 A)	6.00AH
	5 hour rate (1.20 A)	6.00AH
	2 hour rate (3.00 A)	6.00AH
	1 hour rate (6.00 A)	6.00AH
	0.5 hour rate (12.00 A)	6.00AH
Capacity affected by Temperature	40 °C (104 °F)	98%
	25 °C (77 °F)	100%
	0 °C (32 °F)	85%
	-20 °C (-4 °F)	70%
Self Discharge	Approximately 1.5% per month (25°C (77°F))	
Charging Methods	Full Charge	Constant-Voltage Charge: Initial charging current: less than 1.2A Voltage: 14.40 V ~ 14.60 V at 25 °C (77 °F)