

Physical Specification (mm)

Nominal Voltage		12V
Nominal Capacity(20HR)		28Ah
Dimension	Length	196 ± 2mm(7.72inches)
	Width	132 ± 2mm(5.20inches)
	Container Height	160 ± 2mm(6.30inches)
	Total Height(with Terminal)	186 ± 2mm(7.32inches)
Weight With Acid		Approx 8.4Kg(18.5lbs)
Acid		1.280 ± 0.015g/cm ³ (25° C)
Standard Terminal		4
Cell layout		1
Hold-Down		B0
Case		Black-Material (PP)
Cover		Black-Material (PP)
Handle		/

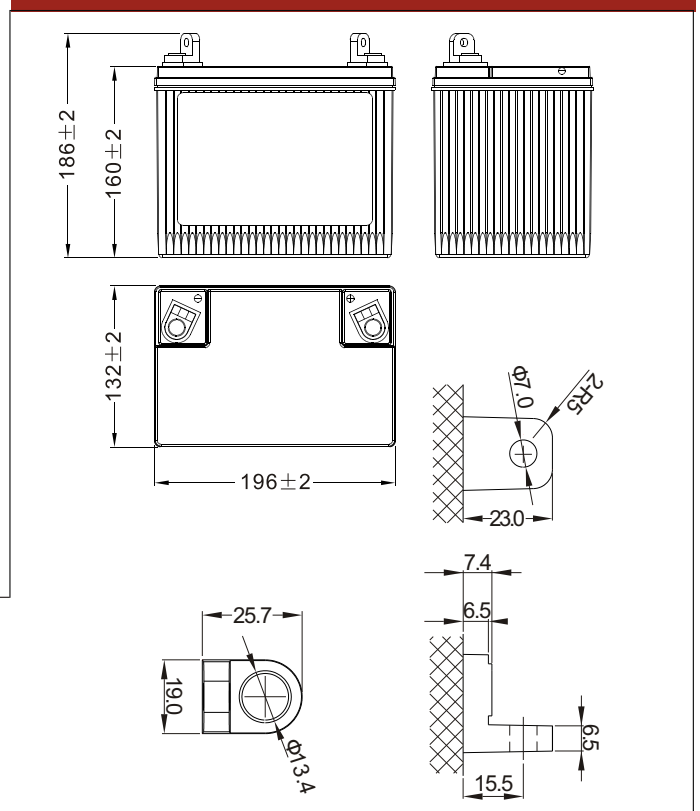

Dimensions (mm)



Electrical Specification

Rated Capacity	20 hour rate(1.4A)	28Ah
Reserve Capacity (CA)25A@10.5V		35min
Cold Cranking Performance Amps(CCA) @0° F(-18° C)		265A

Cell Layout

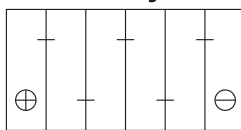

Figure(1)

Discharge Characteristics

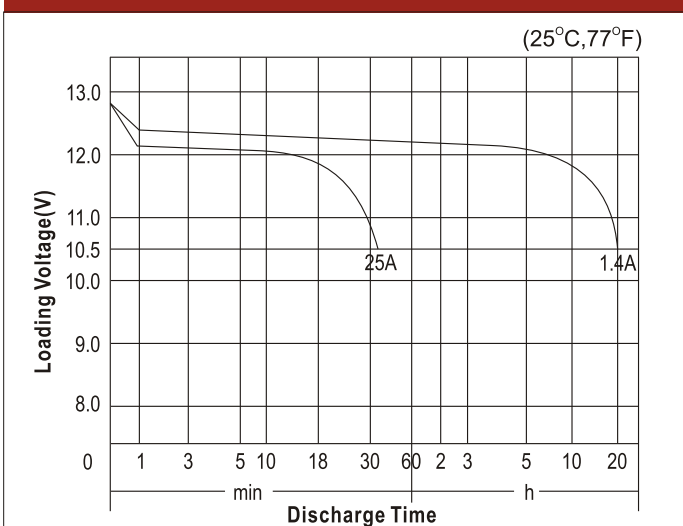

Discharge Characteristics

